

- NOTES:**
1. PLC REFERS TO PROGRAMMABLE LOGIC CONTROLLER.
 2. PEM REFERS TO PROTON EXCHANGE MEMBRANE ELECTROLYSER STACK
 3. THE RECTIFIER IS REPRESENTED BY THE DIODE SYMBOL
 4. K1, K2, K3 ARE POWER CONTACTORS
 5. L1, L2, L3 ARE THE THREE ELECTRIC PHASES
 6. PLC1, PLC2, PLC3 ARE THE LOGIC GATES OF THE PLC (OUTPUT)

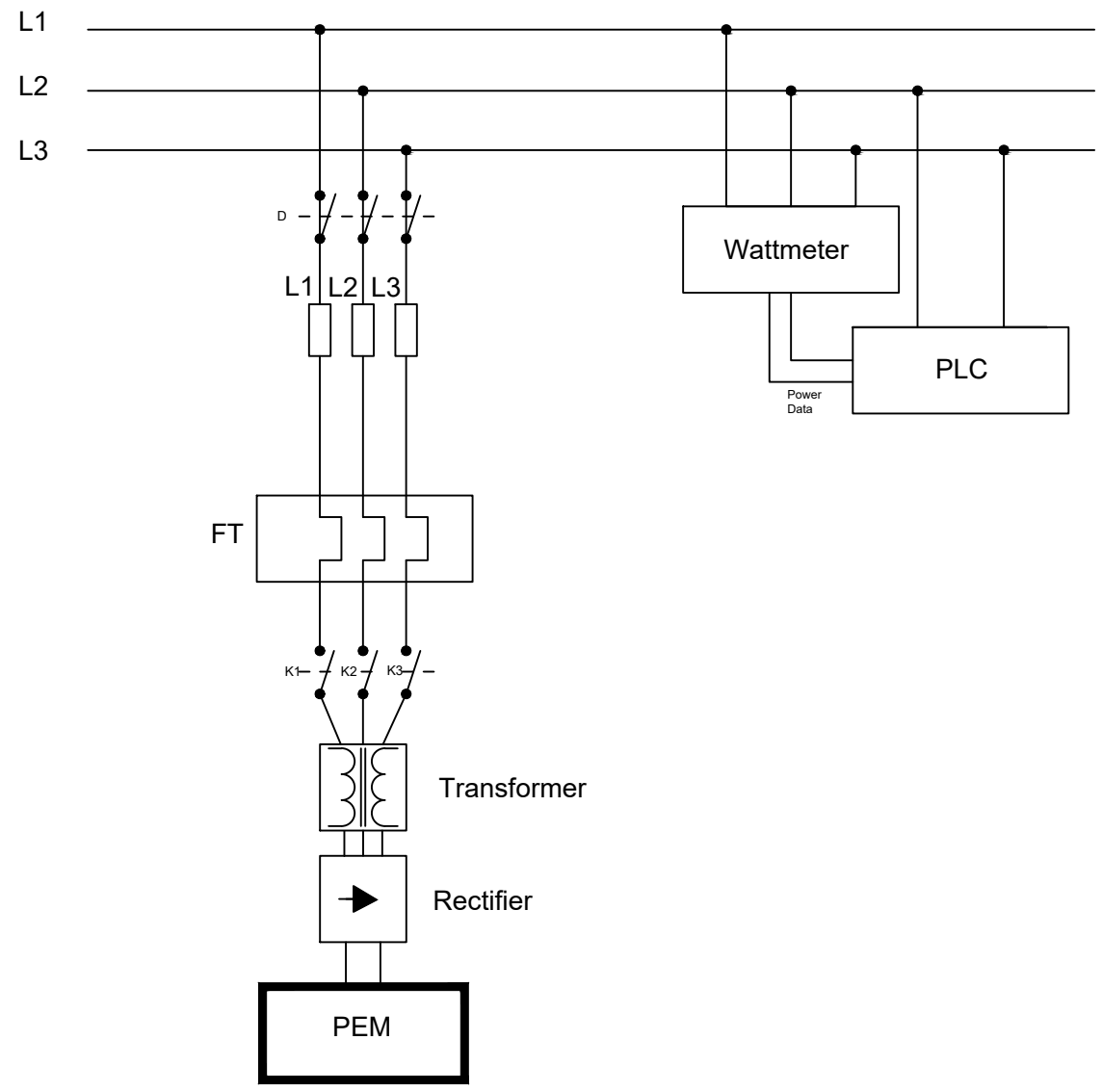

POWER CIRCUIT

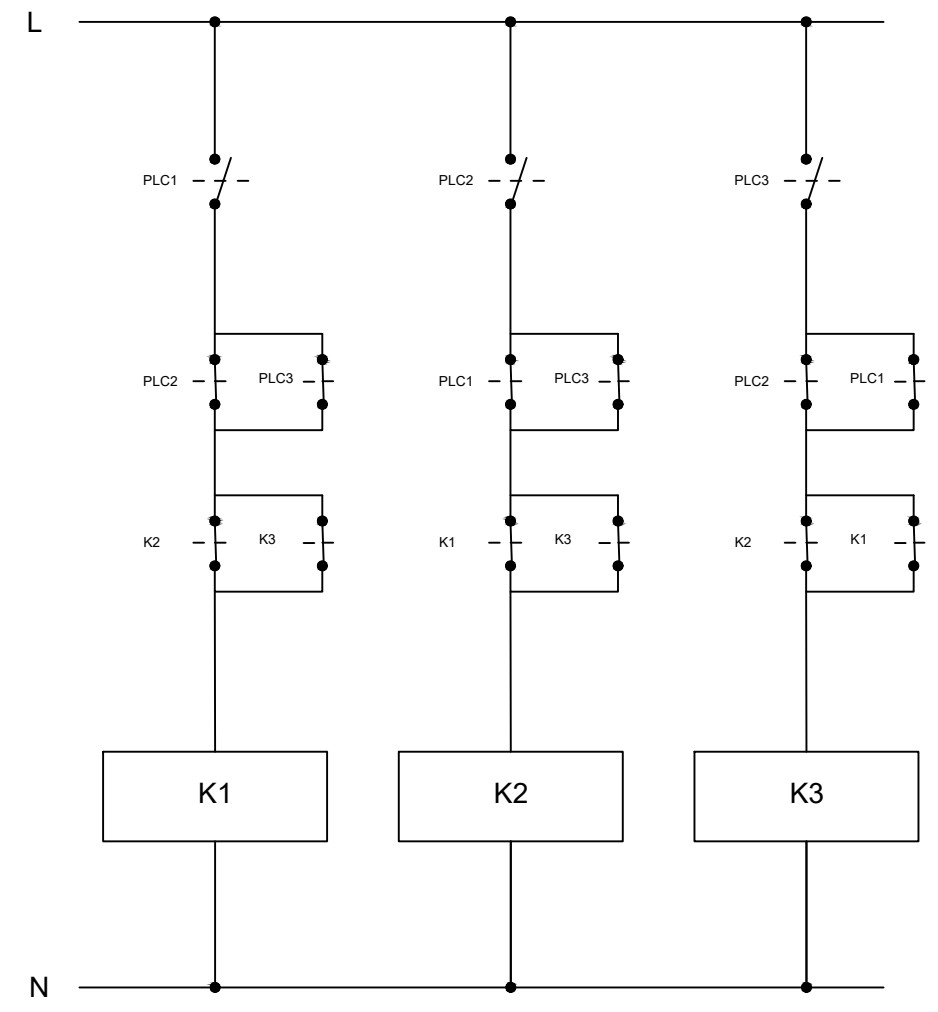

CONTROL CIRCUIT

NO.		REFERENCED DOCUMENTS & DRAWINGS	REV.	DATE
DRAWN		RAUL RIBEIRO	19/04/2020	
CHECKED				
APPROVED				
TITLE		POWER AND CONTROL CIRCUITS FOR INTEGRATED PROCESSING PLATFORM		
SIZE	A3	DWG NO.		
SCALE		DRAWING NO.	1	REV A
				SHEET 1 OF 1